

Model: SH180

Data

Type: Hermetic scroll compressors

Producer: Danfoss-Maneurop

Series: SH

Model: SH180

Technical data

Displacement [m ³ /h]:	29,6
Swept volume [cm ³ /rev]:	170,2
RPM [min ⁻¹]:	2900
Weight [kg]:	106
Oil charge [dm ³]:	6,7
Oil type:	160SZ
Maximum system test pressure low side / high side:	30/45
Maximum number of starts without softstart [1/h]:	12
Refrigerant charge limit [dm ³]:	13,5
Sound power [dB]:	80
Refrigerant:	R410A

Connections

	<u>milimeters</u>	<u>inches</u>
Suction connection with supplied sleeve:	41	1 5/8"
Discharge connection with supplied sleeve:	35	1 3/8"

Model: SH180

Capacity

R410A

Cooling capacity [W]

$t_c \setminus t_e$	-25	-20	-15	-10	-5	0	5	10	15
20	18 733	23 157	28 366	34 462	41 545	49 717	59 077	-	-
25	17 494	21 836	26 928	32 869	39 761	47 704	56 800	67 149	-
30	16 241	20 480	25 431	31 196	37 874	45 566	54 375	64 399	75 742
35	14 975	19 089	23 878	29 443	35 885	43 305	51 803	61 481	72 440
40	-	17 666	22 270	27 613	33 797	40 921	49 087	58 396	68 949
45	-	16 211	20 608	25 707	31 610	38 416	46 228	55 145	65 270
50	-	-	18 895	23 727	29 327	35 793	43 227	51 731	61 405
55	-	-	-	21 675	26 948	33 052	40 087	48 155	57 355
60	-	-	-	-	24 477	30 196	36 809	44 418	53 123
65	-	-	-	-	-	27 225	33 395	40 522	48 710

Power input [W]

$t_c \setminus t_e$	-25	-20	-15	-10	-5	0	5	10	15
20	6 831	6 777	6 744	6 719	6 690	6 645	6 572	-	-
25	7 656	7 571	7 518	7 485	7 459	7 428	7 380	7 303	-
30	8 567	8 442	8 361	8 311	8 279	8 254	8 223	8 174	8 095
35	9 592	9 420	9 302	9 226	9 179	9 151	9 128	9 099	9 051
40	-	10 530	10 367	10 256	10 188	10 148	10 124	10 106	10 080
45	-	11 802	11 584	11 432	11 331	11 271	11 239	11 223	11 210
50	-	-	12 983	12 779	12 638	12 549	12 500	12 477	12 470
55	-	-	-	14 325	14 136	14 010	13 935	13 897	13 887
60	-	-	-	-	15 853	15 681	15 571	15 511	15 488
65	-	-	-	-	-	17 591	17 437	17 345	17 302

Current [A]

$t_c \setminus t_e$	-25	-20	-15	-10	-5	0	5	10	15
20	22.37	21.38	20.73	20.39	20.30	20.41	20.67	-	-
25	22.71	21.68	20.99	20.58	20.41	20.42	20.58	20.81	-
30	23.23	22.18	21.45	21.00	20.77	20.71	20.78	20.91	21.07
35	23.94	22.88	22.14	21.66	21.39	21.27	21.27	21.33	21.39
40	-	23.79	23.05	22.56	22.26	22.12	22.06	22.06	22.05
45	-	24.90	24.18	23.70	23.40	23.24	23.16	23.11	23.04
50	-	-	25.55	25.09	24.81	24.65	24.56	24.48	24.38
55	-	-	-	26.74	26.49	26.35	26.26	26.18	26.06
60	-	-	-	-	28.44	28.34	28.28	28.21	28.09
65	-	-	-	-	-	30.62	30.61	30.57	30.47

Model: SH180

Capacity

Mass flow [kg/h]

$t_c \setminus t_e$	-25	-20	-15	-10	-5	0	5	10	15
20	327.07	403.60	490.87	590.69	704.88	835.26	983.66	-	-
25	319.34	396.46	484.41	585.00	700.06	831.40	980.84	1 150.20	-
30	310.55	388.17	476.69	577.96	693.78	825.97	976.35	1 146.74	1 338.96
35	300.62	378.62	467.63	569.46	685.94	818.88	970.10	1 141.42	1 334.66
40	-	367.74	457.13	559.43	676.46	810.05	962.01	1 134.16	1 328.32
45	-	355.45	445.11	547.78	665.26	799.40	951.99	1 124.87	1 319.84
50	-	-	431.49	534.41	652.26	786.83	939.96	1 113.46	1 309.15
55	-	-	-	519.26	637.35	772.27	925.83	1 099.85	1 296.15
60	-	-	-	-	620.47	755.63	909.52	1 083.96	1 280.77
65	-	-	-	-	-	736.82	890.93	1 065.69	1 262.91

C.O.P. [W/W]

$t_c \setminus t_e$	-25	-20	-15	-10	-5	0	5	10	15
20	2.74	3.42	4.21	5.13	6.21	7.48	8.99	-	-
25	2.29	2.88	3.58	4.39	5.33	6.42	7.70	9.19	-
30	1.90	2.43	3.04	3.75	4.57	5.52	6.61	7.88	9.36
35	1.56	2.03	2.57	3.19	3.91	4.73	5.68	6.76	8.00
40	-	1.68	2.15	2.69	3.32	4.03	4.85	5.78	6.84
45	-	1.37	1.78	2.25	2.79	3.41	4.11	4.91	5.82
50	-	-	1.46	1.86	2.32	2.85	3.46	4.15	4.92
55	-	-	-	1.51	1.91	2.36	2.88	3.46	4.13
60	-	-	-	-	1.54	1.93	2.36	2.86	3.43
65	-	-	-	-	-	1.55	1.92	2.34	2.82

Operating conditions: superheating: 11.1 K, subcooling: 8.3 K

t_c - Condensing temperature [°C]

t_e - Evaporating temperature [°C]

Application range

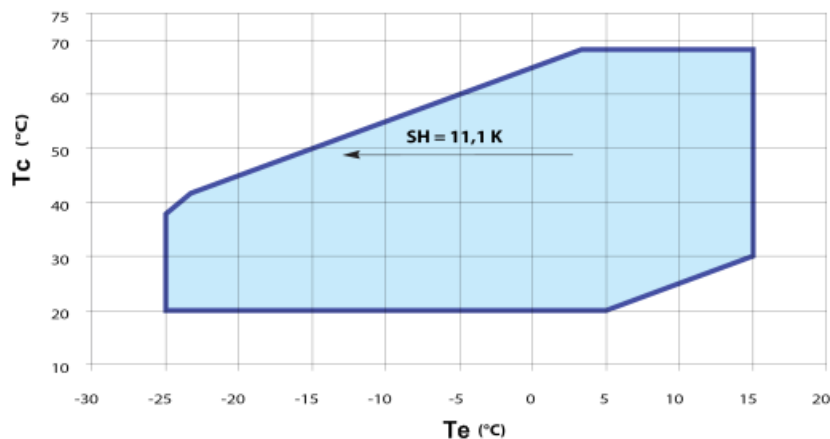

Model: SH180

Dimensions

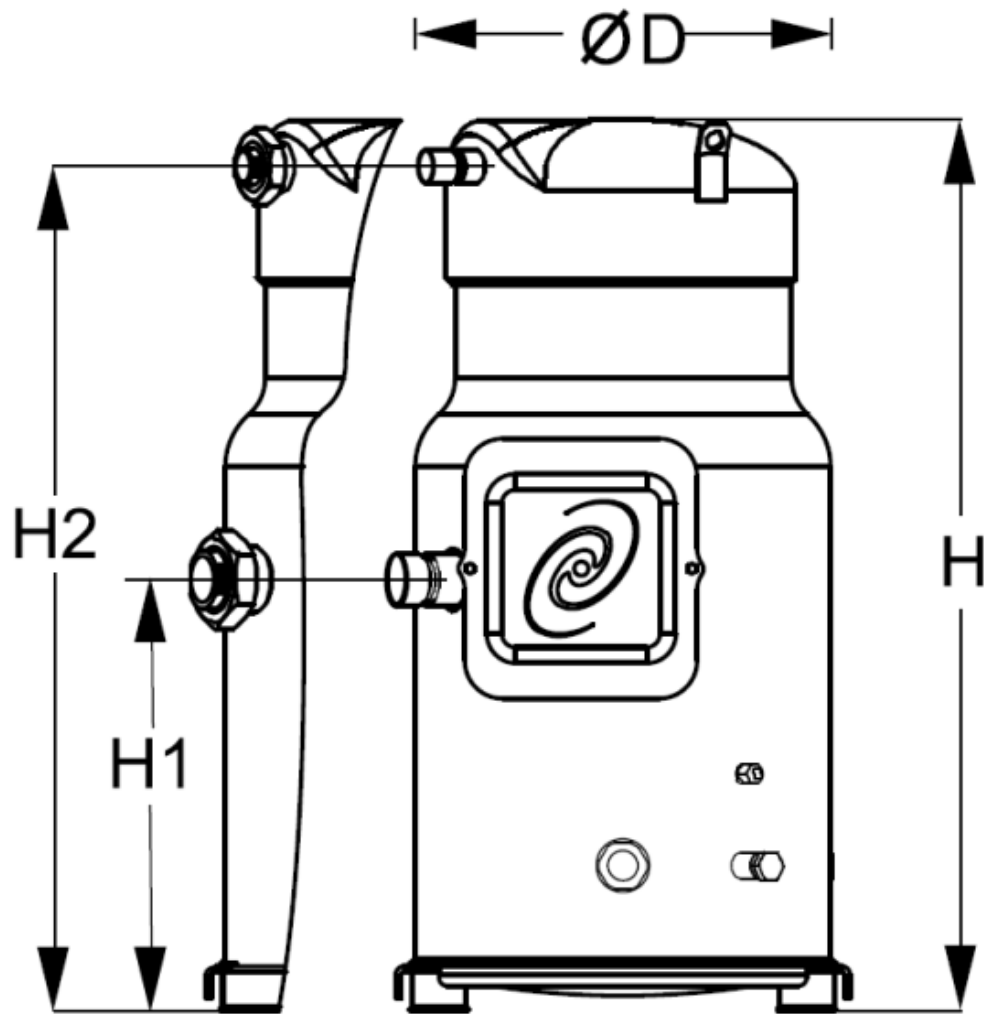

D [mm]: 317,8
H [mm]: 682
H1 [mm]: 330,5
H2 [mm]: 646,5

Model: SH180

Image



Single phase power supply

Motor voltage code: 4
Power supply: 400V/3/50Hz
Maximum Continuous Current (MCC) [A]: 32,1

Wiring diagram with pump-down cycle

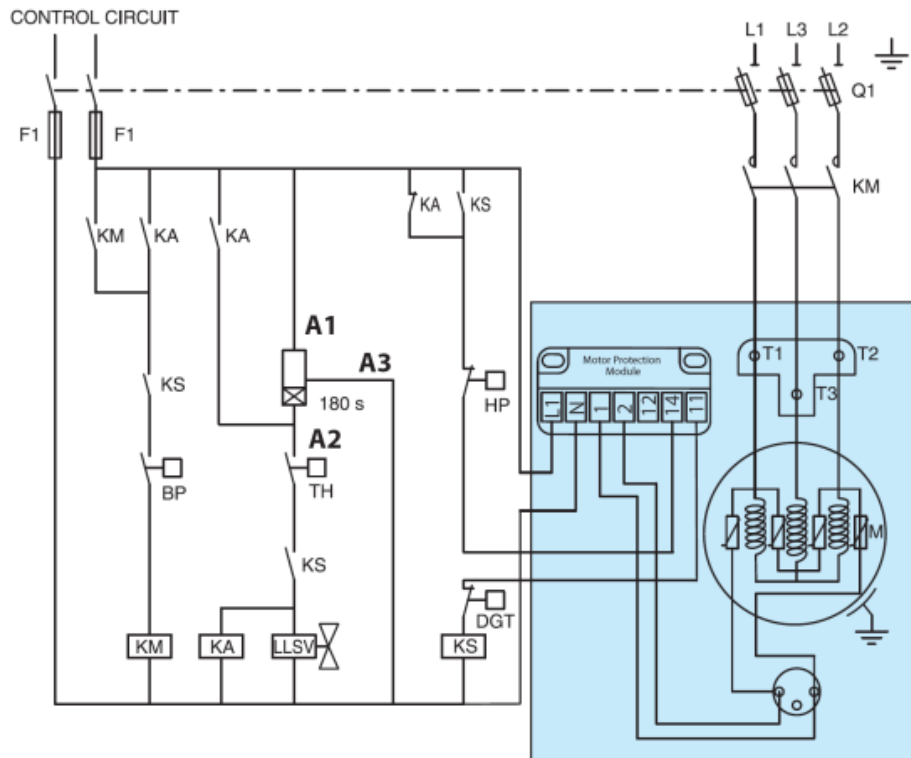

- TH: Control device
- 180 s: Optional short cycle timer (3min) 5 pts
- KA: Control relay
- LLSV: Liquid Line Solenoid valve
- KM: Compressor contactor
- KS: Safety lock out relay
- BP: Pump-down control and low pressure switch
- HP: High pressure safety switch
- Q1: Fused disconnect
- F1: Fuses / S: External overload protection
- F2: External overload protection
- M: Compressor's engine
- thM: Motor safety thermostat
- DGT: Discharge gas thermostat
- MPM: Motor Protection Module
- S: Thermistor chain

Wiring diagram without pump-down cycle

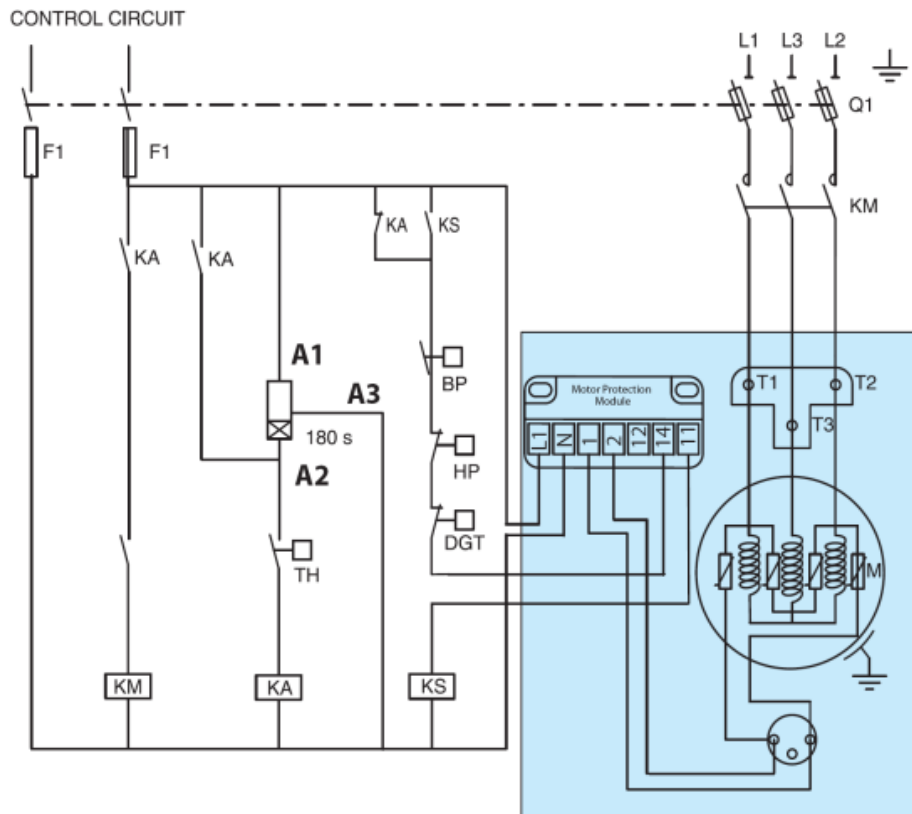

TH: Control device

180 s: Optional short cycle timer (3min) 5 pts

KA: Control relay

LLSV: Liquid Line Solenoid valve

KM: Compressor contactor

KS: Safety lock out relay

BP: Pump-down control and low pressure switch

HP: High pressure safety switch

Q1: Fused disconnect

F1: Fuses / S: External overload protection

F2: External overload protection

M: Compressor's engine

thM: Motor safety thermostat

DGT: Discharge gas thermostat

MPM: Motor Protection Module

S: Thermistor chain